

Redding T-7

Turret Head Removal & Installation

Turret Head Removal

Using a 5/16" Hex Key Wrench, remove the Turret Stud by turning it counter-clockwise (standard right-hand threads). The Turret Stud is torqued to 45 ft./lbs. at the factory and requires similar effort to remove. We recommend adapting a 5/16" Hex Key to a socket wrench to improve leverage. If you plan to store the Turret Head with Dies installed, an extension can be used so that the wrench can be operated above the Dies (without interference). When the Turret Stud is removed, the Turret Head and Turret Bushing can be removed from the Press Frame. Caution should be used when removing the Turret Head as the Detent Ball & Detent Spring are exposed and may become lost.

IMPORTANT: To maintain the proper function of your press, the Turret Head should be stored with the Turret Bushing that was supplied with it. Failure to do so may result in irreparable damage to the Press. To fulfill the need for a convenient Turret Head & Bushing storage solution, the Turret Stacker (Part No. 67950) was developed.

Turret Head Installation

Before installing the Turret Head, wipe the mating surfaces clean with a rag to remove any dirt or debris. With the detent ball and detent spring removed, clean the detent hole with a q-tip to remove any foreign material. Replace the detent spring and ball when finished. Next, apply a quality automotive grease to all mating surfaces, including the turret bushing.

IMPORTANT: The Detent Spring **NEEDS TO BE** installed in the Press Frame **BEFORE** the Detent Ball.

Now, place the Turret Head and Bushing over the Press Frame, aligning the center of the Turret Bushing over the Turret Stud Hole. Next, install the Turret Stud by pushing it through the Turret Bushing and threading it (clockwise) into the Press Frame until it is finger-tight.

Now, use the aforementioned 5/16" Hex Key to torque the Turret Stud to 45 ft./lbs.

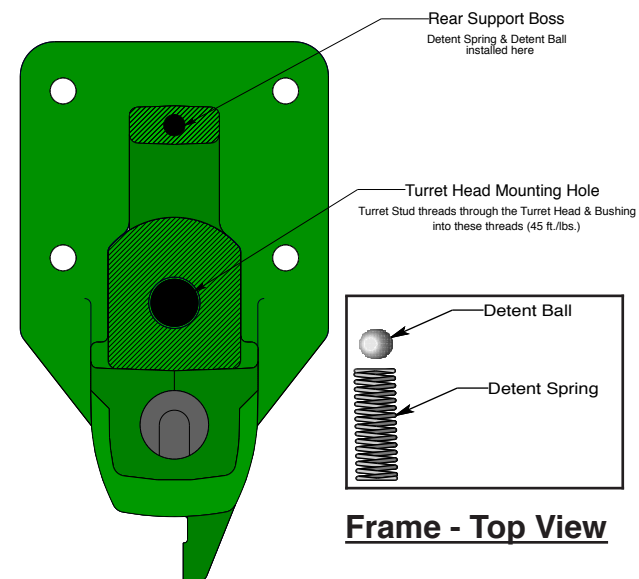
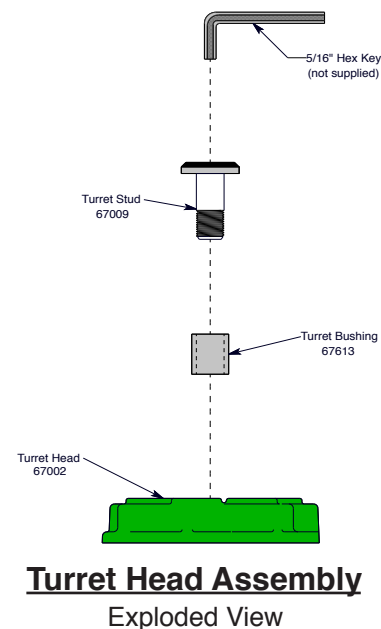

REDDING
RELOADING EQUIPMENT